

PMB-006C

SCHEMATIC DIAGRAM

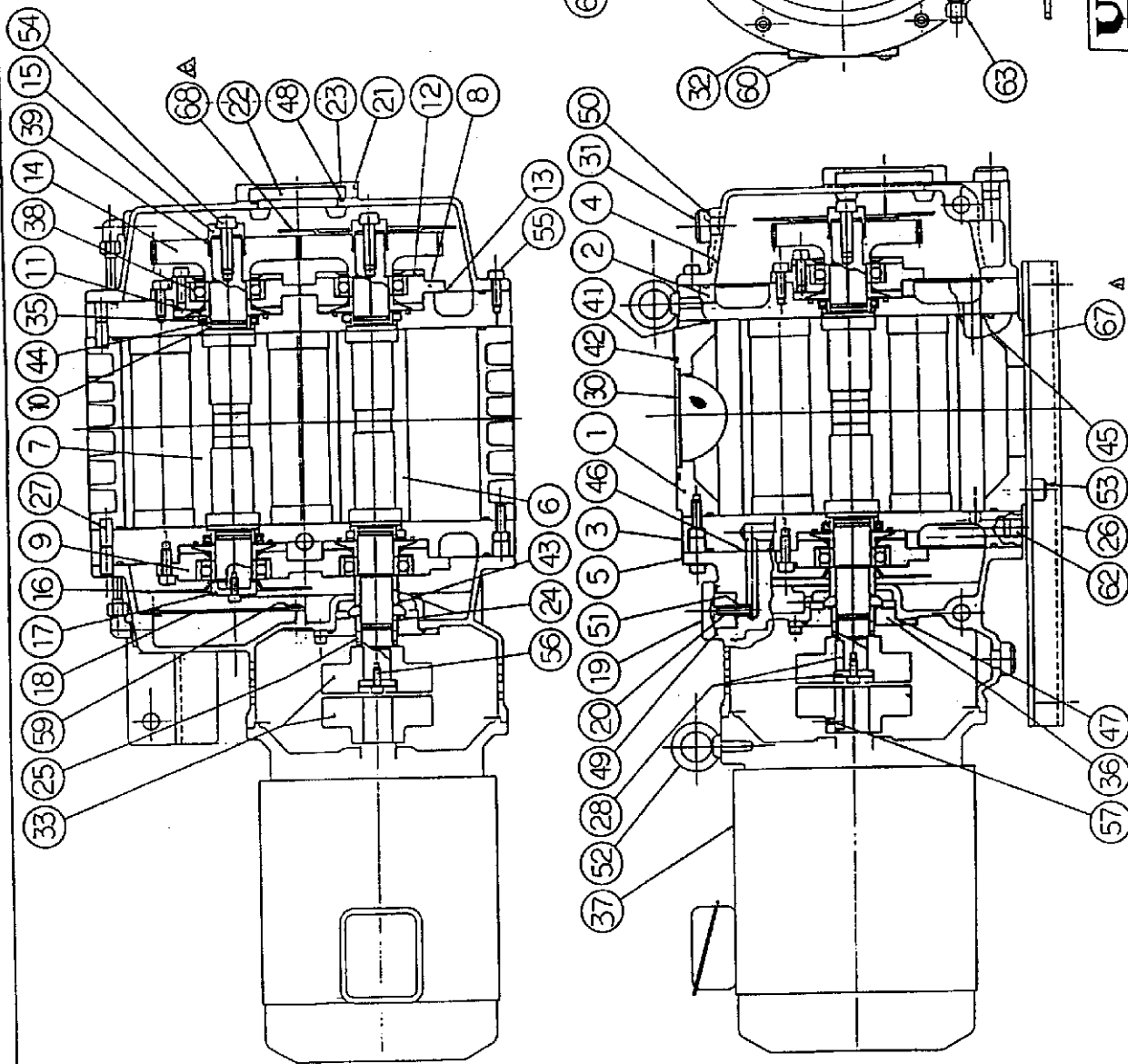

ULVAC DWG. No. ZZ-3150 #A

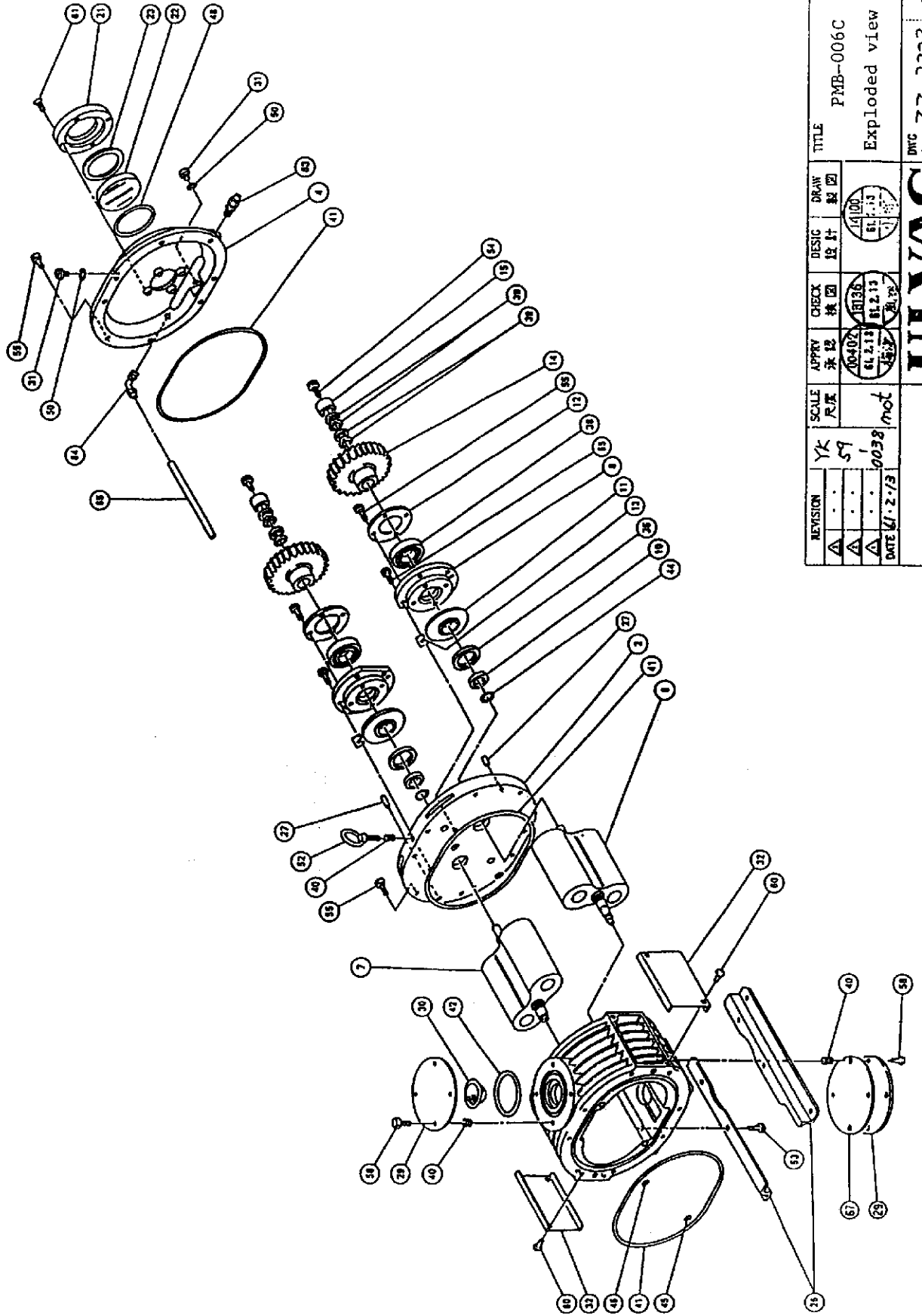

REVISION		Yk	SCALE	APPROV	CHECK	DESIG	DRAW	TITLE	
△	△	59	尺碼	承認	核圖	設計	製圖	PMB-006C	
△	△	0038		00402	18136	11.2.13	11.10.13	Exploded view (1)	
△	△	DATE 11.2.73	mot	11.2.13	11.2.13	11.2.13	11.10.13	DWC No. ZZ-3223-01	

ULVAC

PMB-006C Parts List

No.	Description	Material *1	Q'ty	Remarks
1	Rotor casing	AC4A-T6	1	
2	Gear-side side cover	AC4A-T6	1	
3	Motor-side side cover	AC4A-T6	1	
4	Gear-side cover	AC4A-T6	1	
5	Motor-side cover	AC4A-T6	1	
6	Drive-side rotor shaft	AC4A-T6, S45C	1	
7	Driven-side rotor shaft	AC4A-T6, S45C	1	
8	Gear-side bearing case	FC25	2	
9	Motor-side bearing case	FC25	2	
10	Seal sleeve	SCM435H	4	
11	Slinger	S45C	4	
12	Bearing cap	S45C	2	
13	Spacer	SUS304	1 set	
14	Timing gear	SCM435H	2	
15	Thrust flange	S45C	2	
16	Motor-side oil stirring-up plate	A1000 type	1	
17	Oil stirring-up plate holder	S45C	1	
18	Oil trap cover	A1000 type	1	
19	Oil trap flange (A)	AC4A-T6	1	
20	Oil trap plug (A)	A5000 type	1	
21	Oil level gauge	A5000 type	1	
22	Level gauge glass	Hard glass	1	
23	Level gauge packing	Non-asbestos	1	
24	Mechanical seal sleeve	S45C	1 set	
25	Sleeve nut	S45C	1	
26	Pump support	SS41	1 set	
27	Knock pin	S45C	6	
28	Coupling key	S45C	1 set	
29	Intake port blind plug	A1000 type	2	
30	Intake port mesh	SUS304	1	
31	Drain plug	A5000 type	4	
32	Nameplate	SPCC	2	

No.	Description	Material *1	Q'ty	Remarks
33	Coupling		1 set	
34	-----			
35	Teflon seal		4	
36	Mechanical seal		1 set	
37	2.2kW motor		1	2P, 2.2 kW
38	Bearing	SUJ	4	6206 P5
39	Power lock		4 sets	PL025 × 030E
40	Helisert	SUS	9	M10 × 1. 5DNS
41	O-ring	Fluororubber	4	ISO276
42	O-ring	Fluororubber	1	V100
43	O-ring	Fluororubber	1	S28
44	O-ring	Fluororubber	4	S26
45	-----			
46	O-ring	Fluororubber	5	S12
47	O-ring	Fluororubber	1	G75
48	O-ring	Fluororubber	1	G70
49	O-ring	Fluororubber	1	P32
50	O-ring	Fluororubber	4	P18
51	O-ring	Fluororubber	1	P9
52	Eye bolt	SS41	2	M10
53	Allen screw (hexagon socket head cap screw)	SCM435	4	M12 × 24
54	Allen screw (hexagon socket head cap screw)	SCM435	2	M10 × 35
55	Allen screw (hexagon socket head cap screw)	SCM435	60	M8 × 22
56	Allen screw (hexagon socket head cap screw)	SCM435	16	M6 × 14
57	Hexagon socket set screw	SCM435	1	M6 × 8
58	Hexagon head bolt	SS41	8	M10 × 10
59	Cross-recessed head machine screw	SUS	4	M6 × 8
60	Cross-recessed head machine screw	SS41	4	M6 × 6
61	Cross-recessed head machine screw	SUS	4	M6 × 20

No.	Description	Material *1	Q'ty	Remarks
62	Hexagon socket head tapped plug	SUS	1	PT3/8 (for hydraulic use)
63	Synflex joint	SUS	2	CIN-3/8- PT-3/8
64	Synflex joint	SUS	2	LIN-3/8- PT-3/8
65	Synflex tube	Nylon	1	N2-1-3/8 (blue)
66	-----	-----	-----	-----
67	Exhaust port blind packing	NBR	1	
68	Gear-side oil stirring-up plate	A1000 type	1	

*1 According to JIS standard.